

Evōba[®]
Wood Ceiling System Installation Guide



Sound Ideas. Proven Products.

©2008

Acoustic Ceiling Products, L.L.C.

PO Box 1581 Appleton, WI 54912-1581

800.434.3750 Fax 800.434.3751

acpideas.com

Presentation in this brochure or any other ACP publication is correct to the best of our knowledge at the time of publication. We provide this information in an advisory capacity only. Any advisory recommendations given in our publication must be modified to conform with local codes, conditions and specifications.

Acoustic Ceiling Products, L.L.C. is a member of C.I.S.C.A., C.S.I., and N.H.B.A.

Evoba® is a trademark of ACP.

ACP #WIN-99

Key System Components



Main beam



Cross tee



Wall molding and corner medallion



Panel



Mainbeam clip
(suspension mount shown)



Mainbeam clip
(surface mount shown)

Tools needed

Chalk line
Drill (cordless)
¼" drill bit
Hammer
Miter saw
Pencil
String line(s)
Stud finder
Tape measure
½" to 1" wood chisel
Calculator (optional)
Finish nailer (optional)

Supplies Needed

Brad nails (½") for border tile fabrication
Drywall screws
Finish nails (2 ½")
Hanger wire
Lag-eye screws

***PLEASE READ THIS INSTALLATION GUIDE IN ITS ENTIRETY
BEFORE BEGINNING INSTALLATION***

Evōba[®]

Wood Ceiling System

Installation Guide

for technical support call
800.434.3750

There are two methods for installing the Evoba[®] Wood Ceiling System: surface mount (attaching directly to joists or existing ceiling surface using main beam clips) and suspension mount (attaching the system to joists using hanger wire). Be sure to follow the directions that correspond with your chosen method of installation.

Step 1) Determine the height of the ceiling

If you are using the suspended mount method, in each corner of the room, measure and mark on the wall the desired finished ceiling height (Fig 1).

If you are using the surface mount method, attaching directly to the ceiling joists or existing ceiling surface using the supplied mainbeam clip, measure down 2 ¼" from the ceiling joist or surface and mark on wall, in each corner of the room. (Fig 2).

Use a chalk line to connect the corner marks, snapping out the new ceiling height on each wall. This is the reference point for the top of the wall molding.

Step 2) Install corner medallions

Place the corner medallion so the top of the medallion is level with the snapped chalk line. Use a 2 ½" finish nail to fasten the medallion to the wall (Fig 3).

Repeat in all corners of the room.

Step 3) Install wall molding

Line up a piece of wall molding so the chalk line is just visible above the molding. Butt the wall molding to the corner medallion and nail the molding to the wall

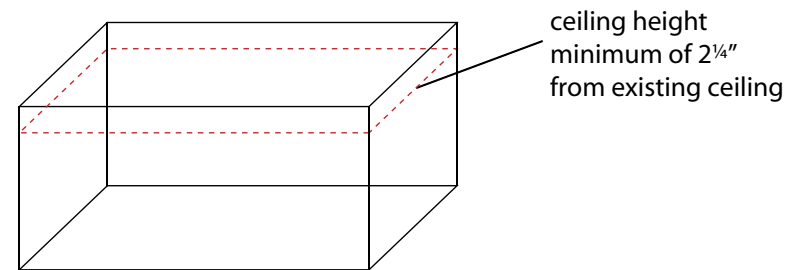

Fig 1

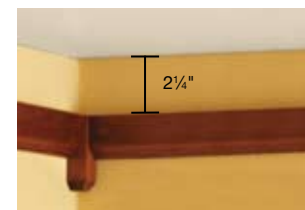

Fig 2



Fig 3

studs using 2 ½" finish nail (Fig 4). Subsequent wall moldings can be installed by abutting the factory-cut square edges. Alternatively, the molding ends can be mitered for a more seamless joint. Repeat these steps until you complete the entire wall and meet at the opposite corner medallion. Repeat this process on all walls of the room.



Fig 4

Step 4) Layout of main beams

The following instructions are for a full ceiling application. For a tray or soffit application, please see page 7.

Determine whether to install the first main beam in the room's center or to install two main beams on either side of the centerline. This will ensure your border tiles are as wide as possible to best utilize materials and aesthetics. There are two layout options. You will need to perform the calculations for both methods to determine the best layout option (Figs 5 & 6).

Layout option 1—On one wall running parallel to the ceiling joists, measure the distance from wall to wall. Establish and mark on the wall the center point. Measure, in inches, the distance from the center point to opposite wall. Using a calculator if needed, divide this distance by 25.5. The resulting number is the number of rows of tiles required to span half the room.

For example, let's assume we have a room that is 14'-7" (175") from wall to wall. $175 \div 2 = 87.5$ to center point. Divide this number by 25.5 (the distance from center to center of each row). $87.5 \div 25.5 = 3.43$. This means that each half of the room needs about 3½ rows of tiles (3 full tiles and 0.43 remainder).

Layout option 2—To determine your best layout option, you must also consider whether materials and aesthetics are best utilized when two main beams are installed an equal distance from the center point (as opposed to option 1, where the main beam is installed directly on the center point). To do this, subtract 12.75 from the center point measurement (87.5 in our example). $87.5 - 12.75 = 74.75$. Divide by 25.5 ($74.75 \div 25.5 = 2.93$). This means that each half of the room will need almost 3 full rows of tile (two full tiles and 0.93 remainder).

In our example, layout option 2 is the best use of materials and will achieve the best appearance. Whichever number is the larger remainder is the best option (.43 in option 1, .93 in option 2).

OPTION 1

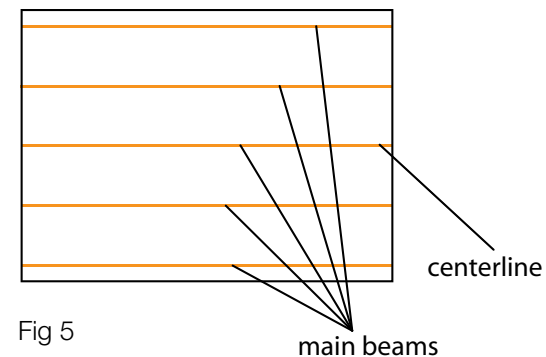

Fig 5

OPTION 2

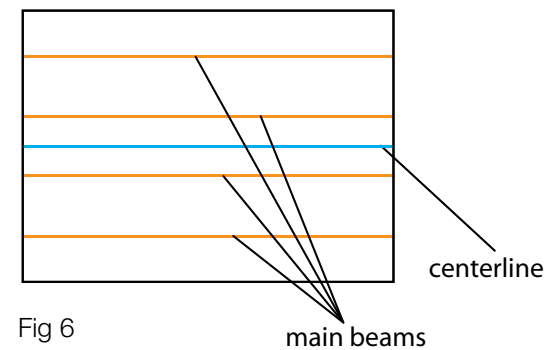

Fig 6

If using *layout option 1*, snap a line in the center of the ceiling (or on joists) perpendicular to the joists. Then measure over in $25\frac{1}{2}$ " intervals on both walls on each side of the centerline until you reach the opposite walls. Snap chalk lines to mark main beam layout (Fig 7, 8, 9).

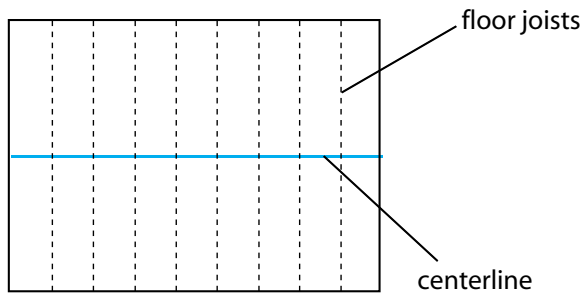

Fig 7

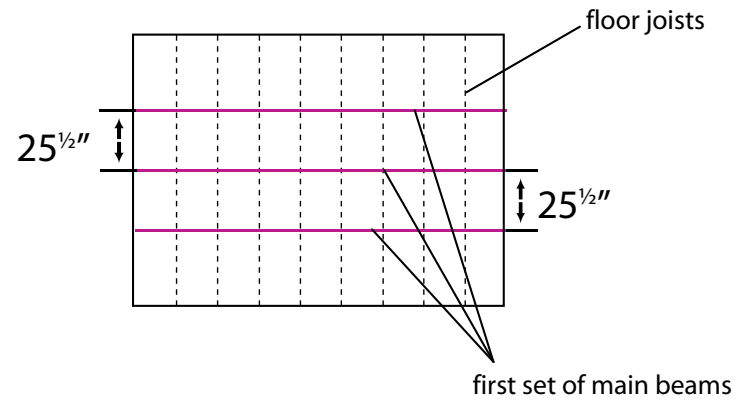

Fig 8

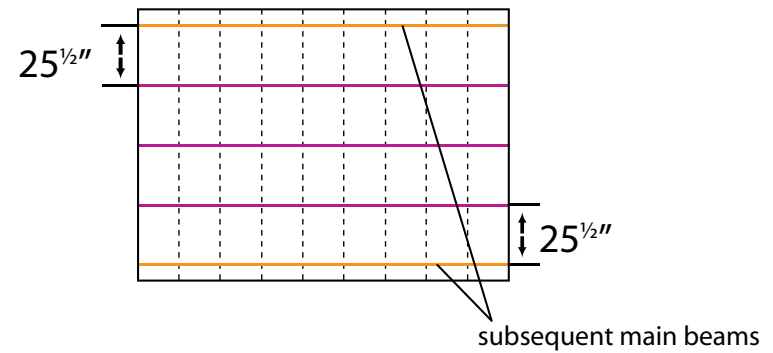

Fig 9

If using *layout option 2*, measure over $12\frac{3}{4}$ " from both sides of the centerline to determine the first two main beam locations. Then measure over in $25\frac{1}{2}$ " intervals on both walls on each side of the centerline until you reach the opposite walls. Snap chalk lines to mark main beam layout (Fig 10, 11, 12).

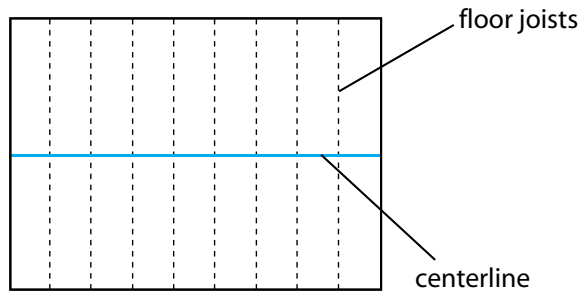

Fig 10

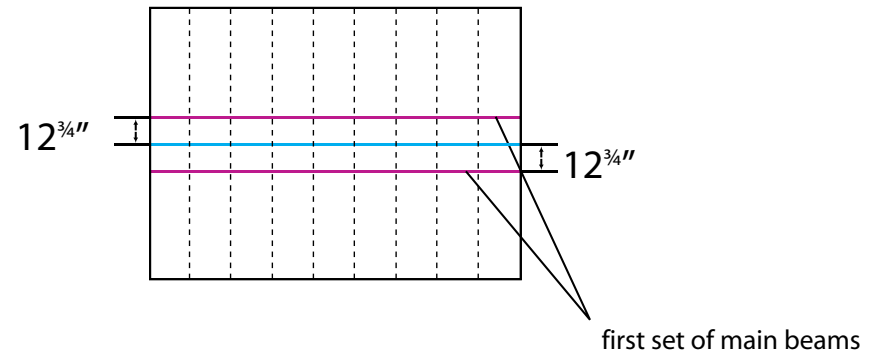

Fig 11

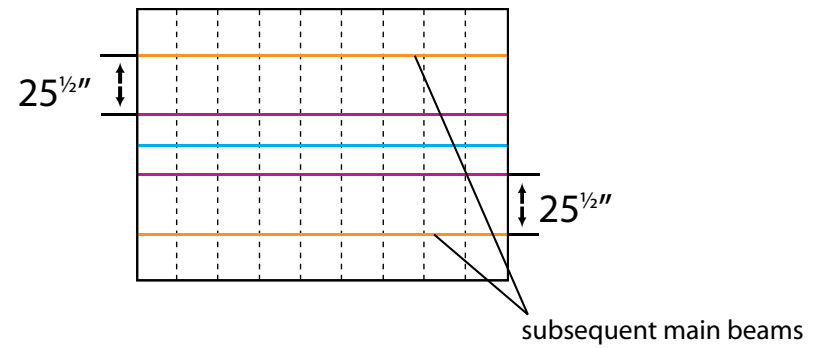

Fig 12

When building a soffit or tray ceiling and using **only full-sized panels**, follow these instructions.

To calculate the size of a tray or soffit ceiling where Evoba is used, add the distance from the wall (or other termination point) plus the distance from center-to-center between the main beams and cross tees.

The distance from a wall or termination point to the center of the first main beam is 25".
 The distance from center-to-center between the main beams is 25 ½".
 The distance from a wall or termination point to the center of the first cross tee is 25".
 The distance from center-to-center between the cross tees is 25 ¼".

For example, let's say you are going to install a tray ceiling that has 4 rows of mains (distance A) and 5 rows of cross tees (distance B).

Distance A - $25" + 25 \frac{1}{2}" + 25 \frac{1}{2}" + 25" = 101"$

Distance B - $25" + 25 \frac{1}{4}" + 25 \frac{1}{4}" + 25 \frac{1}{4}" + 25" = 125 \frac{3}{4}"$

The installation itself will proceed according to normal instructions.

Step 5) Install hanger wires *(suspended system only)*

For surface mount installations, which do not require hanger wires, go directly to the surface mount installation instructions in Step 6.

Hanger wires must be spaced no more than 48" apart and must be attached directly to the ceiling joists, or through the drywall ceiling into the joists above, on every-other joist.

Starting at one end of the room, mark the center of the first joist nearest the wall. From this point, mark the center of every-other joist where the main beam chalk line intersects it (Fig 14).

Repeat this process with each main beam chalk line. Screw in the lag eye screws at the locations specified above.

Tie hanger wire to the lag eye screws by wrapping wire around the lag eye three times. Bend the tag end of the hanger wires 90° at the desired ceiling height so they are parallel with the ceiling above (Fig 15).

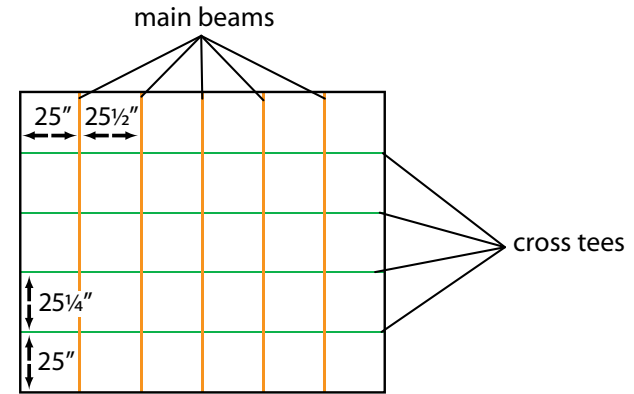
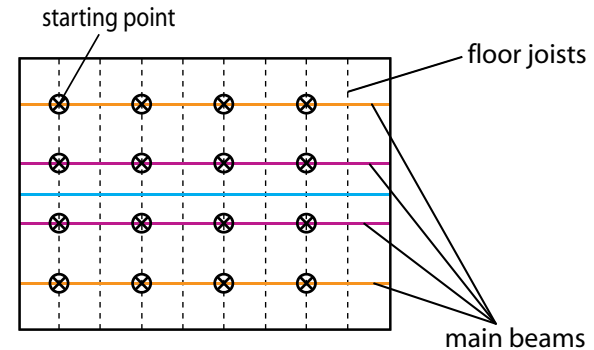

Fig 13



⊗ = hanger wire placement points

Fig 14

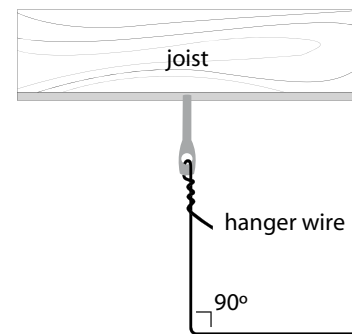

Fig 15

Step 6) Install main beams

For both suspended and surface mount installations, follow these steps.

For the first main beam to be installed in each row, a “tongue” will need to be created on one end so that main beam can rest on the wall molding (Fig 16a). Follow these steps to create the tongue:

- (a) Measure $1\frac{1}{16}$ " and make a pencil mark. Then, using a miter saw, cut the face of the main beam until the blade hits the spline (Fig 16b).
- (b) Using a wood chisel, chisel off the face of the main beam (Fig 16c), leaving the entire spline. This will create the tongue that will rest on the wall molding (Fig 17).

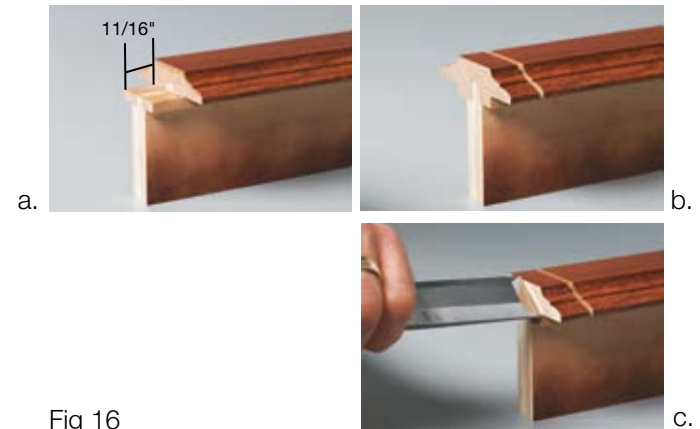
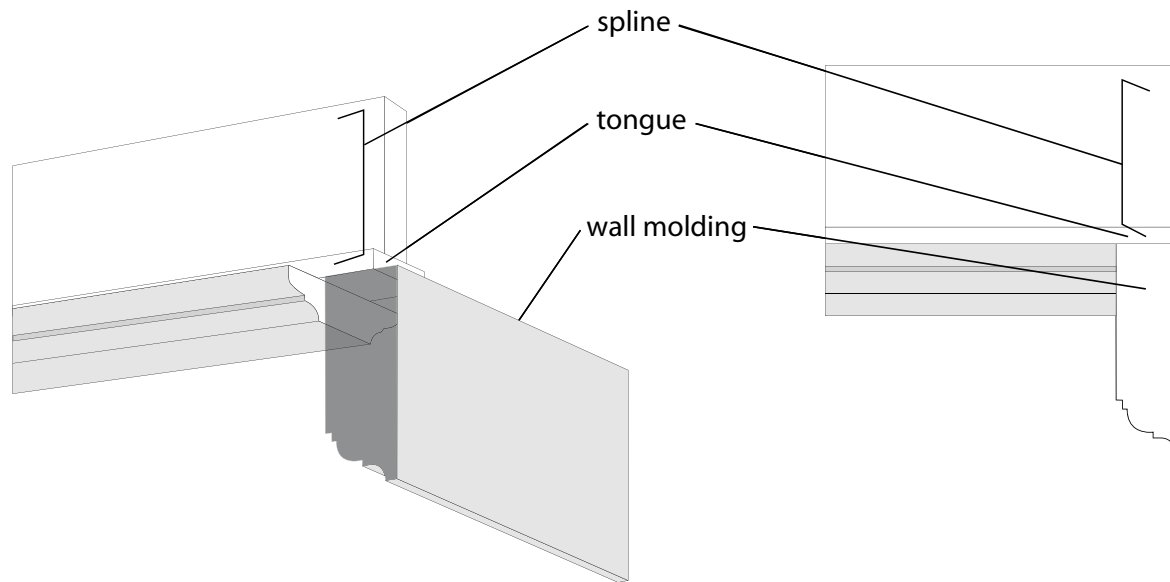

Fig 16

Fig 17



For surface mount installation, follow these steps.

Depending on your layout method from step 4, attach the first main beam(s) using the main beam clip, installing the clips a maximum of 48" apart. It is recommended that the clips be attached at the middle and the ends of each main beam. Attach clips to main beams first and then to the joists.

Note: If you are attaching to drywall or other finished surface, make sure you attach the clip to the framing and not just the drywall.

To establish the exact distance between main beams, use a 2' cross tee as a spacer (Fig 18). Push subsequent beams against the cross tee to make a tight joint and attach the main beam clip to the ceiling joist. Attach all the remaining main beams parallel to the first centerline beam until you are within 23" from the outside wall. Use cross tees as spacers between each main beam.



Fig 18

For suspended systems, follow these steps.

Span a string line perpendicular to the main beam layout lines on the opposing walls 2 1/4" above the top of the wall molding. This string line will establish a level ceiling height reference at the top of the ceiling system. Multiple string lines are recommended for spans longer than 12'.

On the main beam, starting from the end that has the tongue, measure the distance from the wall to the first lag eye screw (see Step 5). Mark this point on the main beam. This will be the first hanger wire intersection point.

Next, measure the distance between the centers of each lag eye screw, transferring each measurement to the main beam. These points designate subsequent hanger wire intersection marks.

On the main beam spline, measure 1" down from the top of the spline at the hanger wire intersection marks (Fig 19a), and drill a 1/4" hole through the spline (Fig 19b).

Rest the tongue of the main beam on top of the wall molding and insert and adjust the hanger wire so the main beam is level with the string line (Fig 19c). Wrap the wire around itself three times. (Fig 19d) Repeat this process at each intersection point to suspend the entire main beam.

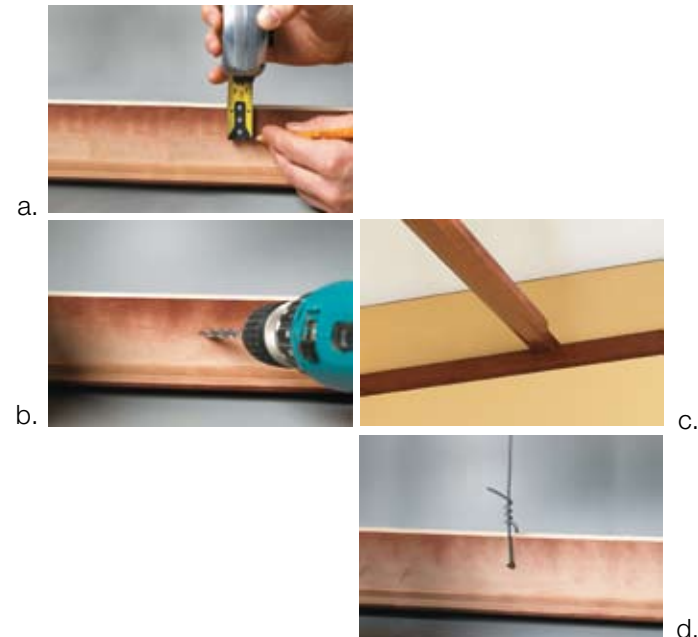

Fig 19

Step 7) Connecting main beams

If the remaining distance to the wall is greater than 8', install the subsequent main beams as noted below. If the remaining distance to the wall is less than 8 feet, measure from the end of the first installed main beam to the wall opposite where the beam's tongue will rest. Cut the final main beam in the row to the length you just measured (Revisit Step 6 if necessary).

Note: This next step is only necessary if the dimension spanned by the main beams is greater than 8'. In such cases, main beams must be connected to span the entire length of the room.

For suspended systems

Measure from the end of the installed main beam to the first lag eye screw where the connecting beam will be installed. Mark this point on the connecting main beam. This will be the first hanger wire intersection point of the connecting beam.

Continue measuring the distance between the centers of each lag eye screw, transferring each measurement to the connecting main beam. These points will designate subsequent hanger wire intersection marks. Mark, drill, fabricate tongue, and hang remaining beams as noted previously in step 6.

Use of main beam clips

Slide the main beam clip over the spline of the two main beams you wish to connect, aligning the beams. Fasten the clip to the main beam splines with $\frac{5}{8}$ " minimum length screws or nails (Fig 20).

Repeat Step 6 (and Step 7, if necessary) with each row of main beams until all are installed.

For surface mount installation

Measure the remaining distance from the main beam to the wall. Cut beam to this length. Fabricate tongue as described in step 6. Attach main beam clips to beam every 4' minimum. See "Use of main beam clips" above for details. Repeat Step 6 (and Step 7, if necessary) with each row of main beams until all are installed.

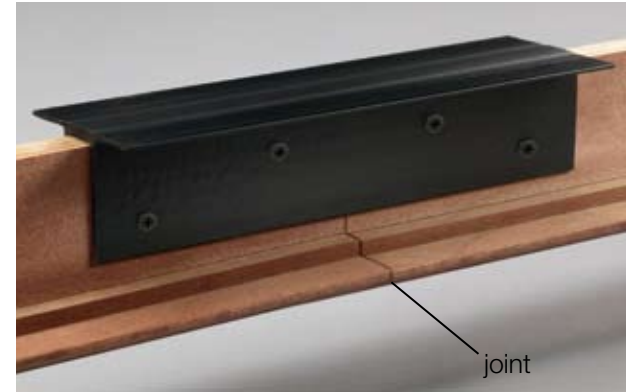

Fig 20

Step 8) Install the cross tees

For both suspended and surface mount installations, follow these steps.

Place the first row of cross tees in the center of the room and work toward the walls. Install the cross tees by inserting at an angle to the main beams and rotating them until they are perpendicular to the main beam.

You will need to cut the cross tees closest to the wall to fit. Measure the distance from the nearest main beam “upper lip” to the nearest parallel wall and cut the cross tee to this length (Fig. 21). Create a tongue on the cut side of the tee so that it will sit on the wall molding (Fig 22). Revisit Step 6 if necessary. Repeat this step for all of the border row cross tees.

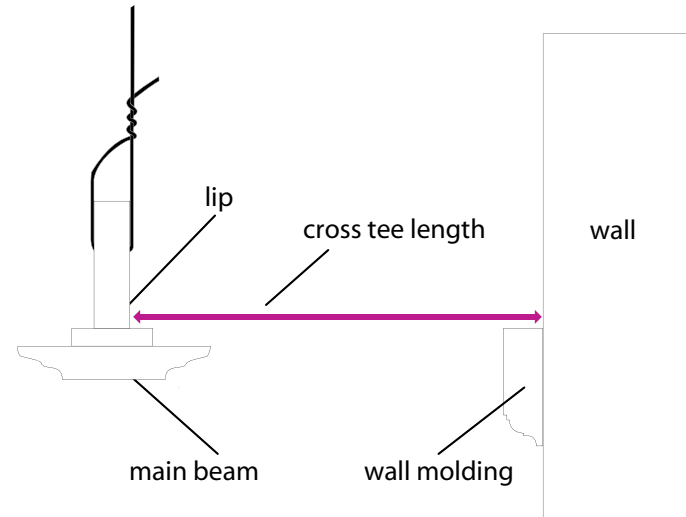

Fig 21

Step 9) Install the panels

Be aware that the grain pattern of each panel is distinct. Many prefer the grain pattern in each panel to be facing the same direction. Others prefer a checkerboard pattern.

For both suspended and surface mount installations, follow these steps.

Start by placing all full-size panels into the grid, starting in the center and working outward. If there are no outside border panels, complete the entire ceiling. If border tiles need to be used, these will have to be cut to size. See Step 10 below.

For the surface mount installation, the tiles are fabricated with a back-cut relief that allows for low-clearance insertion. Slide the cross tees over far enough to tilt and insert each panel between the main beams (Fig 23). Place panel to its highest point and then adjust the panel position until it rests properly on the main beam and cross tee supports. Center panels between the main beams. Once each new panel is in place, slide the cross tee back to its proper location. Repeat until the row is complete.

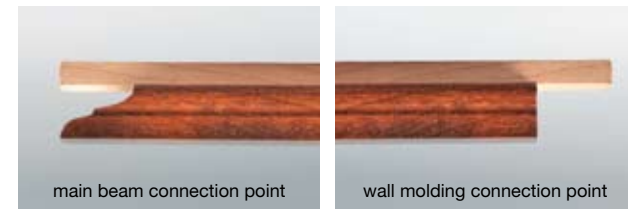

Fig 22



Fig 23

Step 10) Fabricate and install border panels

For both suspended and surface mount installations, follow these steps.

If it has been determined that your project will require border panels, you will receive extra frame and flat panel stock components with your order.

Determine the border panel dimension by measuring from the inside edge of the wall molding to the closest edge of the nearest main beam (or cross tee depending on the direction of the layout). Add 1" to this measurement (Fig 24). This distance will represent the finished outside width of the border panel.

Example: if the distance from the last main beam to the nearest parallel wall molding is 9", the full width of the border panel will be 10".

Miter-cut two of the panel frame components so that the longest dimension equals the calculation above (Fig 25).

Using 1½" finish nails, fasten the panel frame together as you would a picture frame (Fig 26).

Cut the 23¾" by 23¾" flat panel stock to the size of the border panel and nail to the back flat section of the panel frame (Fig 27). Be careful that nails don't protrude past the frame or panel into the finished area. A ½" brad nail works well here. Repeat this step to create as many border panels as you need (Fig 28).

Place the border panels into the grid to complete the ceiling.

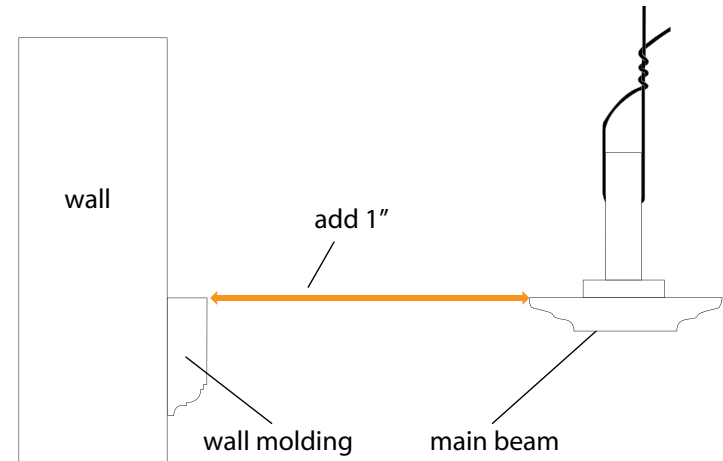

Fig 24

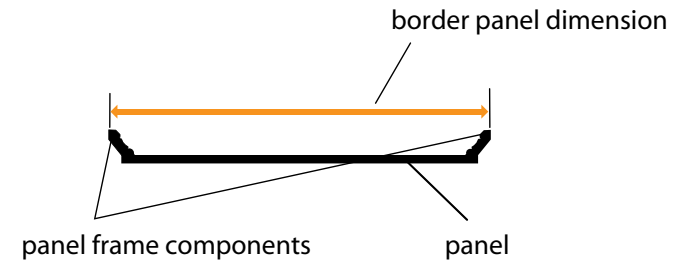

Fig 25



Fig 26



Fig 27



Fig 28